



The AT Messenger

bringing technology to you

Delaware Assistive Technology Initiative (DATI) • Volume 18, No. 1 • 2010

DATI Receives Grant for Educational AT

The Delaware Department of Education recently awarded DATI funding for the purchase of assistive technology (AT) aimed at improving access to educational opportunities for students with disabilities throughout the state. As a result, teachers and students now have greater access to tools that increase communication skills, make print materials more accessible, enhance comprehension, and support teacher-student interactions.

Many of the new devices, listed below, were purchased in multiples so that they can be readily available throughout the state for demonstration and loan purposes. Teachers, parents, and students are encouraged to contact their local ATRC to learn more about the available equipment. Do call in advance of your visit to make sure that the AT Specialist can set aside adequate time to assist you and also to make sure that the products you wish to explore are available on site.

Inside this issue:

<i>More Inventory Additions for Education</i>	2
<i>Help Stop the Spread</i>	3
<i>Homegrown in Delaware</i>	4
<i>Wheelchair Measurement Guide</i>	5
<i>Fair Housing Discrimination Against People with Disabilities</i>	6
<i>The AT Bargain Basement</i>	7
<i>Communication Devices Available</i>	9
<i>Save the Date</i>	10
<i>Delaware AT Exchange</i>	11
<i>Modified Motorcycle Update</i>	13
<i>delAware: A Newsletter of Interest</i>	14

AAC

Vantage Lite

Prentke Romich Company (pictured)

DynaVox V

DynaVox Mayer-Johnson

GoTalk20+

Attainment Company

GoTalk Button

Attainment Company



Vantage Lite



TechSpeak 32

TechSpeak 32

AMDi (pictured)

SpringBoard Lite

Prentke Romich Company

Eye Talks

Enabling Devices

Lightwriter

SL40

Toby Churchill Ltd.

Tobii C8

Tobii ATI (pictured)



Tobii C8



iPod Touch with Proloquo2go

iPod Touch with Proloquo2go

Apple Inc. and AssistiveWare (pictured)

DATI Receives Generous Grant (continued)

Computer Related

2GB Pulse™ Smartpen

Livescribe, Inc. (pictured)



Pulse Smartpen

Other

Lottie Kit for Little Kids

Onion Mountain Technology, Inc.

Hands on Money Kit

Attainment Company



Meville to Weville

Interactive Brailled talking crayons

independent living aids, LLC

Kindle

Amazon.com, Inc.

Meville to Weville

AbleNet, Inc.

(pictured)

Pal Pads (membrane switches, various)
Adaptation, Inc. (pictured)

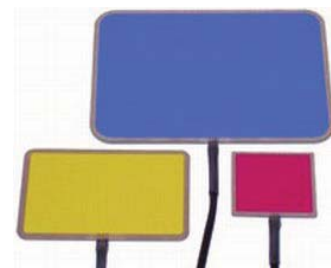

Pal Pads

Smart Start Story Paper

Onion Mountain Technology, Inc.



Reader Digital Book

HTC Touch Pro mobile PDA phone with Mobile Speak for Windows

HTC Corp. and HumanWare

Flexible Switch

Adaptation, Inc.

Reader Digital Book

Sony Electronics Inc.

(pictured) ■

More Inventory Additions for Education

Computers, software, and cool tools like iPods are revolutionizing instruction for *all* students, yet they can be especially helpful to students who struggle with learning because they can make content more accessible and engaging. In addition, because they are “mainstream” products, their use is not at all stigmatizing. DATI is well-known for stocking assistive technologies in its statewide inventory, but it is equally important that we have general purpose technologies for folks to explore and try.

Frequently, educators learn about new tools but do not have the opportunity to try them out in the context of the classroom before actually making a purchase. That’s about to change, thanks to funding from the Delaware Department of Education (DOE). In addition to the items described in the previous article, DOE has made it possible for the DATI to add a number of general purpose technologies to its inventory. For example, a variety of computers—ranging from tablets to netbooks to iPods—is available. These computers offer exciting features such as large touch screens, handwriting recognition, and super-portability. Accessories such as multimedia projectors and network cameras are also available,

as is a wide range of software enabling text-to-speech, speech-to-text, innovative instruction, and alternative input and output options.

And iPods, considered entertainment technology by many, actually offer access to “apps” (applications) for a wide range of educational purposes: flashcards, basic and advanced math, books, and even homework reminders. Depending on the nature of the application, these systems can offer text-to-speech capability as well, turning print materials into multimedia products.

New additions to the inventory include:

Computers

Netbook N120s

Samsung

Tablet – TouchSmart tx2z

HP

Touch Smart

IQ800t

HP

Thinkpad

Lenovo

iPod Touch

Apple Inc.



More Inventory Additions for Education (continued)

Software

Access Bundle 5

IntelliTools, Inc.-Cambium Learning Technologies Co. (pictured)



Access Bundle 5

Inspiration, Kidspiration, and InspireData

Inspiration Software, Inc.



Reading Program Bundle

Kurzweil Educational Systems-Cambium Learning Technologies Co.

Clicker 5

Crick Software, Inc.

Solo

Don Johnston Inc.

Cloze Pro

Crick Software, Inc.

Reading Program Bundle

Edmark (pictured)

Kurzweil USB

Other

Network Camera

Panasonic Corp. (pictured)

PowerLite 825

Multimedia Projector

Epson America, Inc.



Network Camera

These products are available for demonstration purposes at all of the ATRCs, but in anticipation of the high demand, borrowing is restricted to those in the education arena: teachers, related service personnel, school AT Specialists, and family members who are borrowing on behalf of a Delaware student. To learn more about these products, get some assistance in comparing features, or to arrange for a short-term equipment loan, contact your local ATRC. ■

PATTY DUKE AND DR. DAVID KESSLER ASK YOU TO HELP STOP THE SPREAD

Ben Shamburger
Social Security
Public Affairs Specialist
Dover, Delaware

Academy Award winner Patty Duke and the former head of the U.S. Food and Drug Administration, David Kessler, M.D., have teamed with Social Security to launch a flu prevention public service campaign. Ms. Duke and Dr. Kessler are featured in a public service announcement letting people know some simple steps they can take to prevent the spread of the flu, as well as the fact that most business with Social Security can be done online by visiting www.socialsecurity.gov.

You've probably heard some of the health tips they have to offer:

- cover your mouth and nose when sneezing or coughing and encourage those around you to do the same;
- wash your hands often with soap and water; and
- get a flu shot.

But Ms. Duke and Dr. Kessler have one health tip you may not have heard: go online to conduct your



Social Security business. If you need service from Social Security, you don't have to visit an office. Many of our services are available online at www.socialsecurity.gov and by phone at 1-800-772-1213 (TTY 1-800-325-0778). For example, you can visit www.socialsecurity.gov to:

- Apply for benefits;
- Use the *Retirement Estimator* to get a personalized estimate of your retirement benefits;
- Get answers to frequently asked questions; and
- Get a replacement Medicare card.

So do your part to stop the spread of the flu. Go online to www.socialsecurity.gov where you can view the new public service announcement yourself. While on the website, you also can check out the online services for yourself by visiting "What You Can Do Online" (on the left side of the page).

So take some precautions this flu season. Go online to www.socialsecurity.gov. It's just what the doctor and Patty Duke ordered. ■



Homegrown in DELAWARE

Imagine: you've injured your lower leg and need to be mobile around your home, work, and community. Crutches aren't a good choice for you, and your environment isn't wheelchair friendly. Must you become a hermit while your leg heals? No! Your search for alternative mobility brings you to a device that you may want to consider: the **Roll-A-Bout**. I bet you're asking yourself what a **Roll-A-Bout** could possibly be. Well, let me tell you about this device that was invented and is manufactured right in our own little state of Delaware.

The *Roll-A-Bout Corporation* has been manufacturing its crutch substitute in Delaware for over 16 years, and, just like the state's nickname, the company is certainly a "small wonder." The **Roll-A-Bout** is the original crutch substitute, often called a knee walker, for lower leg injuries. To use a **Roll-A-Bout**, the patient simply places the knee of the injured leg on the cushioned platform in order to walk and roll. The **Roll-A-Bout** becomes an extension of the injured leg! In fact, it keeps the patient's lower leg 100% non-weight-bearing while allowing them to move about without the use of a wheelchair. As opposed to crutches, the unit's design allows the patient to have a free hand while moving; and both hands free while stationary.

The first **Roll-A-Bout** was manufactured in the basement of a Dover home and was created to help the inventors' friend who was having a difficult time navigating with crutches. Although the original model was assembled from spare parts, the individual's orthopedic surgeon immediately recognized the value and need for such a device. After many conversations



and a lot of research, the *Roll-A-Bout Corporation* was finally formed, a patent was obtained on the device, and things simply grew from there!

The *Roll-A-Bout Corporation* ships units all over the world. The company has grown from a small home-based business in Dover to a large facility just outside of Frederica. When it began producing the **Roll-A-Bout**, only one model was manufactured. As

sales quickly grew, the company realized that other models were needed to fit a widely diverse population. More than a dozen models are now available, suitable for nearly everyone—from the 3'2" playful toddler up to a 7' tall professional basketball player! Some models even feature large, all-terrain tires for those who want to get off the sidewalk and into the gravel or grass.

The company is often asked what type of injury is suitable for the **Roll-A-Bout**, and their response is simple: "any injury below the knee!" The unit keeps the leg and foot supported to aid in the healing of numerous lower leg injuries—broken bones, fractures, heel spurs, dislocations, Charcot Foot, sprained ankles, and ruptured Achilles tendons. The **Roll-A-Bout** also allows for proper healing of diabetic ulcers and infections as it keeps the foot from touching the ground. Individuals with amputations and arthritis may also benefit from the **Roll-A-Bout**.

Since the first **Roll-A-Bout** was built from spare parts in a garage in Dover, over a quarter of a million people have benefited from its safety, mobility, and ease of use. Not a day goes by that the mail



Homegrown in Delaware (continued)

does not bring a thank you note from customers praising how their life was made not just bearable but enjoyable due to their use of the device! Many people postpone their foot surgery because they are afraid of how they will cope afterwards; and others allow their injury to worsen because they do not want to rely on friends and family members following their surgery. With the **Roll-A-Bout**, all their fears and apprehensions can be put to rest as they

simply **Roll-A-Bout** with ease!

Roll-A-Bout Corporation, www.roll-a-bout.com, is located at 3240 Barratts Chapel Road, Frederica, DE 19946. You are welcome to telephone them at 1-302-335-5057, or you may call toll-free at 1-888-736-6151. Their hours of operation are Monday thru Friday, 8:00 am to 5:00 pm EST. Please, don't hesitate to contact them for more information. ■

Wheelchair Measurement Guide

Marvin Williams, ATP, RET
AT Specialist
New Castle County

DATI receives many inquiries from people looking for wheelchairs and a lot of people listing wheelchairs on the AT Exchange. It is always best to get a proper wheelchair fitting from a professional who takes the necessary measurements and determines the type of chair supports best for the user. Knowing that this may not always be possible, however, we're presenting a measurement guide that can be used to obtain the best fit possible without a formal wheelchair fitting. This guide is applicable to both manual and power wheelchairs.

Let's take a look at measuring the person who will be using the wheelchair. There are three critical measurements—hip width, seat depth, and knee to heel length—when seeking the best fit for a wheelchair. The hip width, designated by "A" in the picture at right, provides the minimum width for a wheelchair, but the chair should be about two inches wider than the hip width. In this picture you can see how that measurement should be taken. The person seeking a wheelchair should be seated on a solid surface without sides. This allows the person taking the measurement to obtain an accurate hip width.

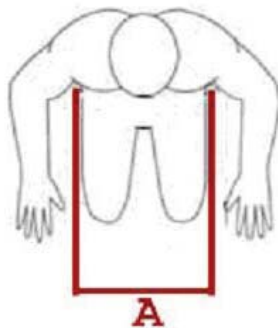

Next, with the individual still sitting on a solid surface, measure the seat depth from behind the person's knee to his/her back, as depicted by the letter "B" in the next picture. The back height (C)

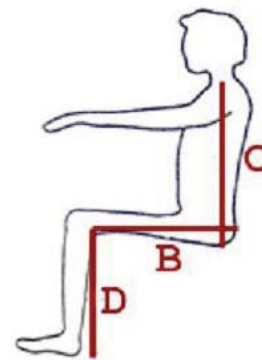

is good to know; however, it's not as important as the other measurements. The letter "D" illustrates the third critical measurement—knee-to-heel length. This will give you an idea of how far the seat of the wheelchair should be from the footrest.

Of course, if you have a wheelchair that was professionally fitted to you, and your body size and function hasn't substantially changed since that fitting, then it may be just as easy for you to measure your chair. The process is the same as above with regards to seat width and depth, as well as seat height from the footrest. The images of the chair are presented for your reference.

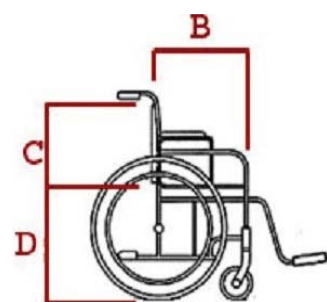
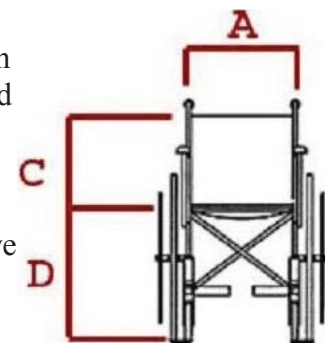

So, if you are in the market for a manual or power wheelchair without the benefit of a professional wheelchair fitting, please take these critical measurements, and don't forget to take your tape measure when you go wheelchair hunting! ■

Community Legal Aid Society Continues to Fight Fair Housing Discrimination Against People with Disabilities

Melissa R. Allman
Staff Attorney
Fair Housing Program

Community Legal Aid Society, Inc. (CLASI) is a nonprofit agency that represents people with disabilities, low-income, and elderly clients throughout Delaware. For a number of years, CLASI has been persistently battling housing discrimination throughout Delaware in an effort to preserve the rights of applicants, tenants, and home buyers to decent and affordable housing. This article focuses on housing discrimination experienced by people with disabilities, particularly with respect to the denial of requests for reasonable accommodations.

Disability Discrimination in the Provision of Housing: An Ongoing Problem Nationwide

The Fair Housing Act was amended in 1988 to include protection for people with disabilities against housing discrimination. Under the Fair Housing Act, a person with a disability is defined as someone with a physical or mental impairment that substantially limits one or more major life activities. Despite the remedies available to people with disabilities under the Fair Housing Act, discriminatory housing practices continue to be pervasive. According to a recent HUD report, a record 10,552 Fair Housing discrimination complaints were filed nationally in fiscal year 2008, and 44 percent of those complaints were filed by people with disabilities.

Reasonable Accommodations and Their Importance

Disability discrimination in housing can arise in a number of ways, but one of the most common problems is the failure of housing authorities and other landlords to make reasonable accommodations. A reasonable accommodation is a change or exception to existing rules, policies, practices, or services necessary for a person with a disability to have full use and enjoyment of their dwelling. While the existing practices and policies of a landlord may have a minimal effect on someone without a disability, those same practices and policies may be extremely detrimental when applied to someone who is disabled. Requests for reasonable accommodations include, but are not limited to: waiving no pet policies;

early lease termination because of medical conditions; creation of designated parking spots for people with mobility impairments; unit transfers as a reasonable accommodation; and repayment agreements for people who fall behind on their rent due to their disability.



CLASI has worked hard to educate housing authorities and landlords about the need to be flexible when applying their policies and practices to people with disabilities. In many cases, CLASI has successfully prevented evictions and termination from subsidized housing programs with reasonable accommodations that allow tenants with disabilities to remain and fully enjoy their homes. When necessary, we have filed Fair Housing discrimination complaints with the Division of Human Relations (DHR) and suits in state or federal court.

CLASI Success Stories

In a recent case, a woman living on the third floor of an apartment building was involved in a serious car accident resulting in the amputation of her leg below the knee. After extensive surgery, she had to rely on a wheelchair for mobility. Because the apartment building had only one elevator, which was frequently out of order, she found herself in situations where she could not leave her apartment or get back to her unit after she'd been out. Sometimes she even became trapped in the elevator. During a fire at the complex, she had to be carried down three flights of stairs by a police officer. She requested a transfer to a first-floor unit but was told there was a no-transfer policy. CLASI requested a transfer as a reasonable accommodation but the request was denied and a Fair Housing complaint was later filed with DHR. DHR investigated the complaint and made a finding that discrimination had occurred. CLASI filed suit in Superior Court, and settlement was reached four days before a jury trial. The settlement included an award for the client's damages, attorney fees, and a civil penalty for the state.

In another recent case, a client with severe depres-

Fair Housing (continued)

sion, for which he was receiving Social Security Disability benefits, moved into a public housing high-rise building with a German Shepherd whose weight exceeded the limitation of the housing authority's rental agreement with regards to their pet policy. After allowing the client to live in the apartment with the dog for a year, the manager threatened to evict the client because of the size of the dog. After the client obtained a letter from his treating physician stating that the dog was an emotional support animal, the landlord allowed the dog to remain and permitted the client to take the dog to all parts of the building. Two years later, the client was notified that he could no longer bring his dog into the community room. When the landlord refused to reconsider its position, CLASI filed a Fair Housing discrimination complaint. Unable to reconcile the situation, the landlord refused to recognize the appropriateness of an emotional support animal as an accommodation for an individual with a mental impairment. After DHR issued a cause finding of discrimination, the parties eventually settled. The client received an award for his damages, was permitted to bring his dog into all areas of the building once more, and was transferred to a larger unit.

What To Do If You Have Experienced Fair Housing Discrimination

Although people with physical and mental disabilities in Delaware continue to face both blatant and subtle forms of housing discrimination, it is important for those individuals to pursue the remedies available to them under the federal and state Fair Housing Acts. This is the only way education and change will continue to occur. If you or someone you know has been discriminated against in the provision of housing in the state of Delaware, please contact our Fair Housing Unit, which is located in the Wilmington office and can be reached at 302-575-0660.

The work that provided the basis for this publication was supported by funding under a grant with the U.S. Department of Housing and Urban Development. The substance and findings of the work are dedicated to the public. The author and publisher are solely responsible for the accuracy of the statements and interpretations contained in this publication. Such interpretations do not necessarily reflect the view of the Federal Government. ■

The AT Bargain Basement

Marvin Williams
AT Specialist
New Castle County

Hello friends! Welcome to the *AT Bargain Basement (ATBB)*! I am your master of bargain ceremonies, Marvin Williams, and I'm here to bring you all of the assistive technology I can find for \$100 or less. I also convey those bargains your fellow *Basement* dwellers, fans of the *ATBB*, give me. If you're a regular *Basement* dweller, welcome back! If this is your first time, welcome. We've been waiting for you.

Without further adieu, let's get to the bargains!

My first bargain is the **Carex Universal Attachable Flashlight**. It's a flashlight that can be attached to a cane, walker, wheelchair, crutch, gait trainer...you name it! It doesn't need tools to attach, and it has 14 bright LED's, with a reported range of 17 feet.

This little marvel is powered by three AAA batteries, so no odd, hard-to-get battery sizes to worry

about. This handy item is available on numerous websites for various prices and shipping costs, or lack thereof. *Target's* website, www.Target.com, toll-free at 1-800-591-3869, offers the item for \$8.54 plus shipping and handling. www.Amazon.com, toll-free at 1-800-201-7575, lists it for \$7.22, and it is eligible for free shipping if combined with one



The AT Bargain Basement (continued)

or more other eligible items that total \$25 or more. In fact, *Amazon* suggests a pairing of this flashlight with the **Duro-Med Universal Beverage Holder**, a handy item in its own right. The **Carex Universal Attachable Flashlight** is also available for \$8.92 from www.Walmart.com, or toll-free at 1-800-966-6546. It's currently not available in *Walmart* stores; however, you can save yourself the cost of shipping by using the site's new "site to store" option. This option allows you to order the item on the website and have it shipped to the store nearest you, free of charge, where you can pick it up. This is a nice option if shipping charges make items less of a bargain. Please note that "site to store" is not available for every item, so keep that in mind when you're bargain hunting. But, it is available for this little gem. So, if you can use more light while using your mobility device, this handy little flashlight may be just the thing to do the trick.



My next bargain is also available from www.Walmart.com and it's a combination of handy devices. It's

the **Mobility Reacher, Dressing, and Bathing Kit**. The kit includes a deluxe sock aid, a 22 1/2" Scrubies long-handled bath sponge, a 24" dressing aid stick, a 24" raptor reacher, and a 19 1/2" shoehorn. All of these items can be helpful for someone who recently had a hip or knee replacement. They are also handy for anyone who has a tough time bending to reach for things. This kit is available for \$59.88 and is eligible for "site to store" shipping. A nearly identical kit—the **Duro-Med Deluxe Reach Assist Kit**—is available on www.Amazon.com for \$49.80, and it is eligible for free shipping. *Sammons-Preston* has a similar kit for \$28.75. The **Hip/Knee Equipment Kit** from *Sammons-Preston* does not have the dressing stick, but it does have a sock aid, a 32" reacher, a 16 3/4" shoehorn, and a bendable 18" long-handled bath sponge. This is a bargain at about half the price of the *Walmart* item and about three-fifths the price of the *Amazon*. Be aware that you will have to pay shipping for the *Sammons* kit, so be

ready for the actual price to be a little higher than the list price of \$28.75. You can reach *Sammons* at www.sammonspreston.com or at 1-866-402-8720, toll-free. Make sure to check with them about the shipping charges for your order so you can compare prices fully. I also suggest that you take the time to compare the kits because they vary not only in price but also by lengths and included items.

My third and final bargain in this issue of the *ATBB* is the **16.5X Jeweler's Clip-On Eye Loupe** available from

Harbor Freight Tools. Yes, you read correctly, *Harbor Freight Tools*. This isn't the first bargain I've brought



from this previously unknown haven of assistive technology bargains. This little magnification marvel clips to your eyeglasses and provides you with two magnifying lenses you can swing down into your field of vision for the eye on the side where the loupe is attached. The two lenses are a 3.5X and a 5X, which, working together, provide the 16X magnification. Jeweler's loupes are not for everyone, but if you think it might help you, check it out. It's a bargain at \$4.98, and it's a steal when you can catch one of their sales. I recently saw it listed on sale for \$2.99! Now, not every *Harbor Freight Tools* carries the same stock, so you should check with the one in your area. Currently, Delaware has two store locations—Governor's Square in Dover and University Plaza in Newark. To the best of my knowledge, they don't have mail order available yet; so you still have to visit a store to take advantage of this great buy. They can be contacted, toll-free, at 1-800-444-3353 to inquire about store locations or request a catalog.

That brings this installment of the *AT Bargain Basement* to a close. As always, I'd like to thank you all for reading and invite you to share your bargains and feedback about the column. And if you share your bargains, I'll give you all of the credit while only taking half of the praise! Please join us next time when I'll bring you more bargains than you can shake a cane at! So, until next time, remember, just because it's a bargain, doesn't mean it's cheap! ■

AstraZeneca Donation Makes Communication Devices Available to Delawareans

When speaking is a challenge that seems insurmountable, then it is important to find an alternative means of communication. Enter communication devices of all shapes, sizes, and capabilities. Communication devices, also known as augmentative and alternative communication (AAC) devices, come with a seemingly endless range of functions. They can be low-tech, like the Picture Exchange Communication System (PECS), which uses simple pictures for expressive purposes. High-tech options abound and seem to increase exponentially with expanded capabilities every time you turn around. Then, of course, there are mid-tech communication devices. DATI recently received a sizeable donation of mid-tech devices from *AstraZeneca*, a local company, and we are making them available to Delawareans with disabilities.

AstraZeneca, a Delaware-based pharmaceutical company, developed the **ZAM Communicator**.

This simple communication device was created to positively impact health and communication between patients and medical professionals. The **ZAM Communicator** is two-sided, lightweight, and easily transportable. It enables a person to communicate by spelling out words using a keypad or pressing icons to display a message on a small LCD screen.



The **ZAM Communicator** does not have voice output but offers a double-sided display screen so that someone standing in front of the person using the device can see the text display. This device has a keypad of letters, arranged alphabetically, on one side, along with ten pre-programmed picture buttons—doctor, nurse, hot, cold. Pre-made icons fill the other side of the device and include a simple pain scale along with eighteen buttons that express feelings, needs, and wants—sick, dizzy, thirsty, hungry, glasses, read. All of the picture buttons are

labeled in both English and Spanish. The **ZAM** is rechargeable, but the battery cannot be changed. These devices are available, free of charge, on a first-come, first-served basis to Delawareans with disabilities.



Free is, of course, a great deal, but it is important to know that there are restrictions with regards to who can obtain the **ZAM**. The devices may only be distributed to people with communication limitations. Health care and disability professionals are asked to promote the availability of these devices and direct individuals to contact the Assistive Technology Resource Center (ATRC) in their county. To put it plainly, we cannot distribute these communication devices to professionals. Secondly, even though the **ZAM Communicator** is free, it is not for everyone. Remember, it is a simple device without audio output, and it cannot be programmed. With that said, the ATRC nearest you has a wide range of augmentative and alternative communication (AAC) devices available for you to try out. These devices range from low-tech communication boards with interchangeable pictures to high-tech speech generating devices.

If you or someone you know could use a **ZAM Communicator**, please call, email, write, or send a carrier pigeon to your local ATRC to let them know that you would like to see if the **ZAM** is the device for you. The AT Specialist will set up a time for you to come in, see how it works, and, if you decide it is a good fit, then you will walk out with a **ZAM**. During your appointment, you will also have the opportunity to try out other communication systems and borrow one or more of them at that time. We invite you to call DATI at 1-800-870-DATI (3284) or you may visit www.dati.org and click on the “contact us” button. ■

Save the Date



16th Annual Inclusion Conference
Keys to Inclusion: Unlocking Potential
 Thursday, May 6, 2010
 8:00 am—3:15 pm
 Sheraton Dover Hotel & Conference Center
 Dover, Delaware

Dwelling in Possibility: The Values, Beliefs, & Habits of Inclusive Schools

The keynote is inspired by the words of celebrated poet, Emily Dickinson, who wrote “I dwell in possibility.”

Dr. Kluth will discuss what beliefs, values, and practices associated with inclusion will help educators succeed in educating, challenging, motivating and supporting all learners.

Paula Kluth, Ph.D. is a consultant, teacher, author, advocate, and independent scholar who works with teachers and families to provide inclusive opportunities for students with disabilities and to create more responsive and engaging schooling experiences for all learners. She is a former special educator who has served as a classroom teacher, consulting teacher, and inclusion facilitator. Her research and professional interests include differentiating instruction and supporting students with autism and significant disabilities in inclusive classrooms.



Workshops following the Keynote (one choice for the day)

Joyful Learning: Using Active & Collaborative Techniques to Engage Students	Paula Kluth
Improving Academic and Behavioral Outcomes for Students with Challenging Behavior: Classroom Management Practices that Work!	Peter Alter, University of Louisville
Sensory Integration & Behavior: Understanding the Signs and Strategies to Improve Young Children's Success	Colleen Heckman, Easter Seals
Accessible Instructional Materials: Opening the Curriculum for the Benefit of All Learners	Beth Mineo, DATI; Karen Jones, DOE
Making it Meaningful! Access to the General Education Curriculum for Students with Significant Cognitive Disabilities	Shawnee Wakeman, UNC Charlotte



Audience: Educators, parents, policymakers, service providers, and child care providers involved with or interested in promoting inclusion.

Registration: \$35 fee, \$17.50 full-time students, registration materials will be mailed and available online in February 2010 at:

<http://www.dati.org/events/>

Note: In order for DOE to support substitutes, prior approval is necessary through your district's special education office.

Additional information: Contact Beth Shinn at DATI, 800-870-3284 and select the option for Kent or bshinn@udel.edu, or Sonja Rathel at 302-856-1081 or rathel@asel.udel.edu.

Planning Committee: Birth to Three Early Intervention System, Center for Disabilities Studies at the University of Delaware, Delaware Assistive Technology Initiative, Delaware Department of Education, Delaware Head Start Association, and The Parent Information Center of Delaware

Modified Motorcycle Update

We want to take this opportunity to update you on information that recently came to our attention regarding the “Not Quite Homegrown in Delaware” article in our Winter 2009 issue.

Haus of Trikes is no longer in business, but we’ve learned that several companies may be able to perform motorcycle conversions. If you are interested in having an existing two-wheeled motorcycle converted to a trike, we recommend that you con-

tact your local motorcycle shop to see if they do the work or can point you toward a vendor who can help. There are vendors that make and/or sell three-wheeled motorcycles, if you are looking to buy a new trike, and we understand that Harley Davidson is one such company.

Eddie Jory, the AT Specialist in our Kent County ATRC, would be happy to discuss motorcycle modifications with you. Please contact Eddie by phone or email—1-302-739-6885, eddiej@udel.edu. ■

delAware: A Newsletter of Interest

The Delaware Assistive Technology Initiative (DATI) officially joined the Center for Disabilities Studies (CDS) at the University of Delaware on July 1, 2009. The mission of CDS is to enhance the lives of individuals and families in Delaware through education, prevention, service, and research related to disabilities. The Center promotes independence and productivity so individuals and families can fully participate in the life of the community.



One of the ways the Center educates is through its bi-annual newsletter, *delAware*. It has been a collaborative effort of the CDS and the Delaware Developmental Disabilities Council for more than 15 years, and we are pleased to make it available to DATI consumers.

Each issue of the newsletter has a theme, focusing on a topic of interest to people with disabilities and their families. The current issue, Fall 2009, focuses on various types of family supports and includes an article on how DATI has helped several families achieve improved access to assistive technology. In addition to the DATI article, there are features about other CDS programs that support families, an article about a respite care network resulting from the collaboration of several organizations, and a list of family support resources. The current and previous issues are available on the publications page of the CDS website, www.udel.edu/cds.

If you would like to receive a paper copy of the latest issue, or be added to the *delAware* mailing list to receive future issues, please contact Michele Sands at msands@udel.edu or 1-302-831-3038. The next edition of *delAware*, which will be published in Spring 2010, will focus on transition issues. ■

DELAWARE

Note: If you are looking for items not on the AT Exchange, contact the DATI's Sussex County ATRC at 302-856-7946 or 800-870-DATI (3284). If you call the 800 number, you will interact with an automated system. In order to reach the Sussex ATRC, press 1 after the first prompt and 6 after the next prompt.

New items are added regularly. If there has been no activity or interaction with the contributor to the list within six months, items are automatically removed from the list.

Note on liability: The DATI does not warrant the condition or terms of sale of any device offered for reutilization by an existing owner or borrower under the AT Program. The DATI shall not be liable for any claims, liabilities, damages, losses, costs, expenses (including but not limited to settlements, judgments, court costs and reasonable attorney's fees), fines and penalties, arising out of any actual or alleged injury, loss or damage of any nature whatsoever in connection with the sale or use of any device purchased or sold under the AT Program. It shall be the responsibility of the seller to provide accurate and detailed information about the device's specifications and condition to any buyer. The DATI functions solely as an information-sharing communication channel. ■

To Contact DATI's Central Site office or the ATRC closest to you, call 1-800-870-DATI (3284)

Press
#1 for English or
#2 for Spanish,

then press
#3 for the Central Site office
#4 for the New Castle County ATRC
#5 for the Kent County ATRC
#6 for the Sussex County ATRC

TDD callers: Do not press #1 or #2 and your call will be answered on a TDD line at the Central Site office. ■

DATI Equipment Loan Policy

DATI has a wide variety of equipment at the Assistive Technology Resource Centers (ATRCs) for the primary purpose of demonstration and short-term loan. The policy for equipment loans is as follows:

The standard loan period is two weeks, defined as the day borrowed (e.g., Monday the 10th) to the same day two weeks later (e.g., Monday the 24th). Loans may be extended provided there are no names on the waiting list and/or that an extension will not interfere with an existing reservation. The maximum loan period is four weeks.

A maximum of four devices may be borrowed during any single loan period. However, combinations of devices may be treated as a single device if the components are interdependent—either operationally or because one component is required for the borrower to use another. Equipment loans across state lines are not permitted. Equipment must also remain in Delaware throughout the loan period. ■



Please Keep Us Posted!

Has your address changed? Are you receiving duplicates? Would you prefer to receive the newsletter via email?

If your mailing or email address is incorrect, please type or print your correct information on the form below and forward it to DATI along with your current mailing label or the first page of your electronic newsletter. If you no longer wish to receive this newsletter, visit www.dati.org/news/unsubscribe.html or contact our central office.

Do you know a friend or family member who would be interested in receiving the newsletter? Please provide him/her with the subscription form below. ■

The AT Messenger Subscription Form

I am a Delaware resident; please sign me up to receive *The AT Messenger*

Please cancel my subscription to *The AT Messenger*

Name: _____ Title: _____

Affiliation: _____

Address (check one): Business Residence _____

City/State/Zip: _____

Phone: _____ Fax: _____

Email (check one): Business Residence _____

Format: I have provided my email address above, please send me an electronic version

I prefer to receive a print version of *The AT Messenger* through the mail.

Indicate if an alternate format is needed:

audio tape Braille large print

I am a: person with a disability (please specify) _____

family member of a person with a disability

friend/advocate/colleague of someone with a disability

professional (please specify) _____

interested citizen

other (please specify) _____





Delaware Assistive Technology Initiative
Center for Disabilities Studies
University of Delaware
Alfred I. duPont Hospital for Children
PO Box 269
Wilmington, DE 19899-0269

Address Service Requested

Nonprofit Organization
U.S. Postage
PAID
University
of Delaware

0909-0310

DATI RESOURCE CENTERS THROUGHOUT THE STATE...

800-870-DATI (3284)
dati@asel.udel.edu

New Castle County ATRC
Alfred I. duPont Hospital for Children
203 Administration & Research Bldg.
1600 Rockland Road
Wilmington, DE 19803
302-651-6790
302-651-6794 (TDD)
302-651-6793 (fax)

Kent County ATRC
Easter Seals Kent County Center
100 Enterprise Place, Suite One
Dover, DE 19904-8200
302-739-6885
302-739-6886 (TDD)
302-739-6887 (fax)

Sussex County ATRC
20123 Office Circle
Georgetown, DE 19947
302-856-7946
302-856-6714 (voice or TDD)
302-856-6990 (fax) ■

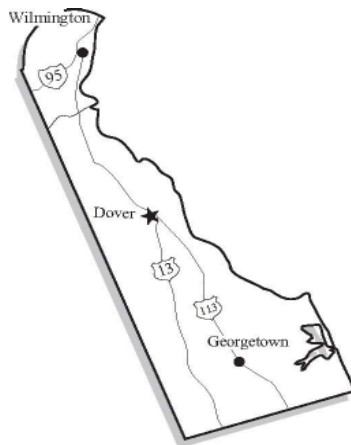

The AT Messenger is published quarterly by the Delaware Assistive Technology Initiative (DATI) at the Center for Disability Studies, University of Delaware. Dissemination of this newsletter to other people, association newsletters, and electronic mailing lists is encouraged. Information contained in this publication may be reprinted without permission, although attribution to the author and DATI is required.

Delaware Assistive Technology Initiative
Center for Disabilities Studies, University of Delaware
Alfred I. duPont Hospital for Children
P.O. Box 269
Wilmington, DE 19899-0269
Phone: 800-870-DATI (3284) or 302-651-6790
TDD: 302-651-6794; fax: 302-651-6793
Email: dati@asel.udel.edu, Web address: www.dati.org

DATI is funded by the Rehabilitation Services Administration (RSA) of the U.S. Department of Education, Grant #H224A050008 to the University of Delaware. This publication does not necessarily reflect the position or policy of RSA/ED, and no official endorsement of the materials should be inferred. The University of Delaware is an equal opportunity employer and prohibits all forms of discrimination as required by Title IX of the Educational Amendments of 1972, Section 504 of the Rehabilitation Act of 1973, Title VII of the Civil Rights Act of 1964, and other applicable statutes ■

